

**PA**EQUIPAGGIAMENTI  
TECNICI  
LAVAGGIOTESTINA SABBIANTE RICOP. PLASTICA  
PLASTIC COVERED SANDBLASTING HEAD**TS3**

①

GB

4

23/09/05

SPECIFICHE TECNICHE  
SPECIFICATIONS

- PRESSIONE NOMINALE RATED PRESSURE	120 bar – 12 MPa (1750 psi)
- PRESSIONE CONSENTITA PERMISSIBLE PRESSURE	140 bar – 14 MPa (2000 psi)
- PORTATA MASSIMA MAX FLOW RATE	20 l/min (5.3 USG p.m.)
- TEMPERATURA MASSIMA MAX WORKING TEMPERATURE	90° C (195 °F)
- MATERIALI MATERIALS	CORPO IN MATERIALE PLASTICO CON CONVOGLIATORE INTERNO IN ACCIAIO TEMPRATO AD ALTA RESISTENZA E SONDA IN ACCIAIO VERNICIATO. MATERIALS: PLASTIC BODY WITH HIGHLY RESISTANT INNER CONVEYOR IN TEMPERED STEEL AND PAINTED STEEL SENSOR.

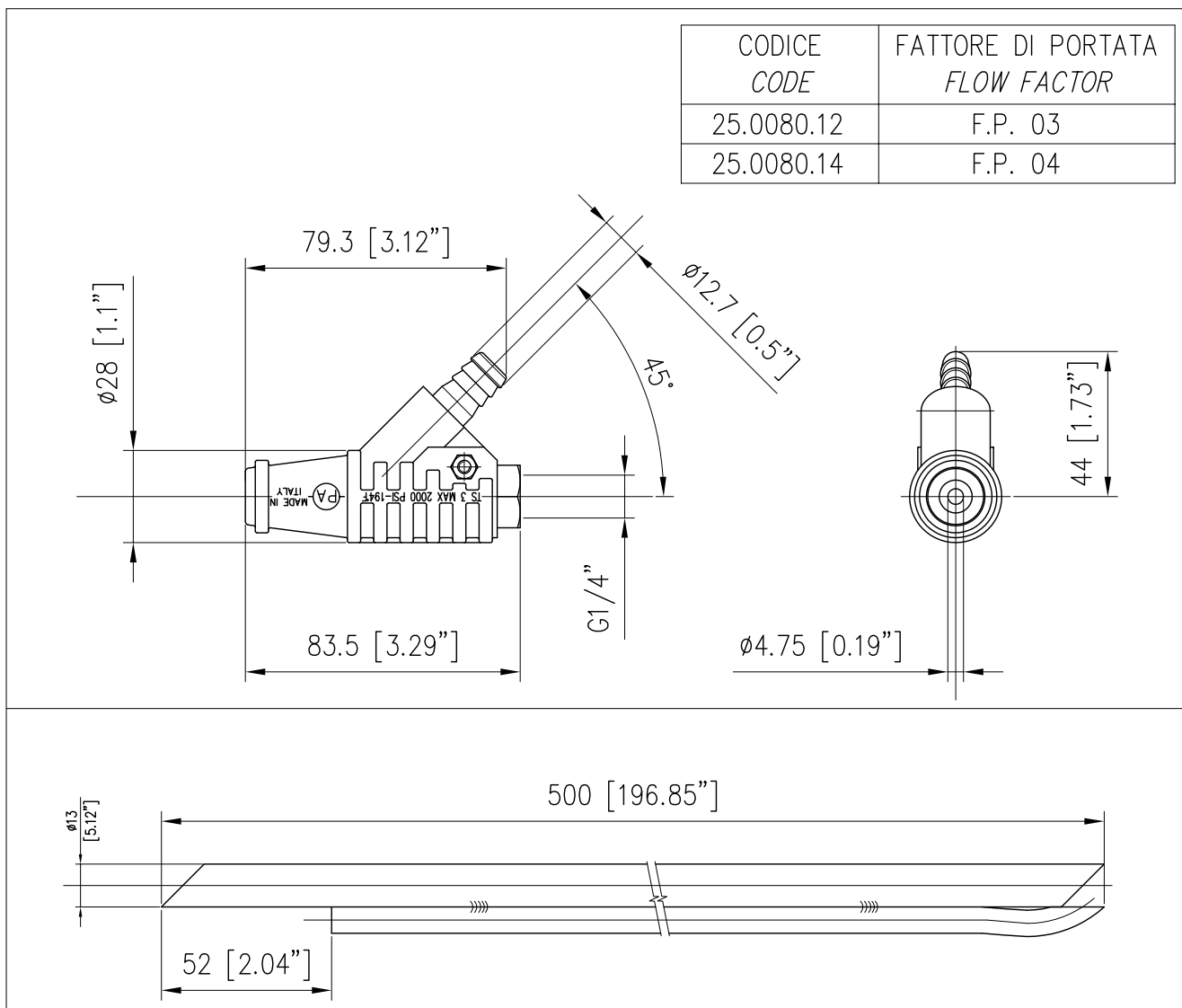
MISURE D'INGOMBRO  
OVERALL DIMENSIONS

25.0080.12 TS3-03 Test. sabbiente, plast.-acc.tratt.zinc.

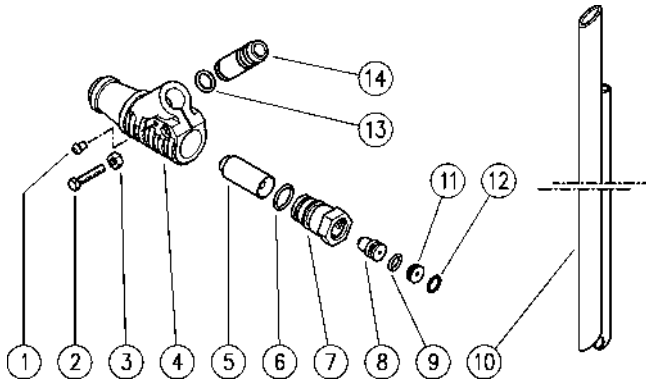

25.0080.14 TS3-04 Test. sabbiente, plast.

Pos.	Codice	Descrizione	Q.tà	K1	K2	K3	K4	
1	15.2000.30	Chiodo 03 bianco	1					10
1	15.2000.40	Chiodo 04 giallo scuro	1					10
2	16.1843.00	Vite DIN7985 M4x20 mm zinc.	1					10
3	11.4513.05	Dado es. M4	1					10
4	25.0081.84	Guscio TS3	1					1
5	25.0083.61	Ug. convogliat. 4,75 mm	1	•				5
6	10.3060.00	An.OR 1,78x12,42 mm	1	•				10
7	25.0082.31	Portaugello TS3	1					3
8	25.0007.51	Ugello 03 d.10,5x15 mm inox	1					5
8	25.0008.51	Ugello 04 d.10,5x15 mm inox	1					5
9	10.3052.00	An.OR 1,78x6,75 mm	1	•				25
10	25.0013.21	Sonda per sabbia +ptgm.13 mm	1					5
11	25.0085.31	Inserto ugello	1	•				5
12	10.3003.00	An.OR 1x8 mm	1	•				10
13	10.3057.00	An.OR 1,78x9,25 mm	1	•				10
14	25.0084.31	Racc. ptgm.13mm TS3	1					1

Kit	Codice	Descrizione	
K1	25.0090.24	Kit ric. TS3 Testina sabb.pz.6x1	1

**25.0080.12 TS3-03 Sandblaster, plast.-zin.hard.steel**

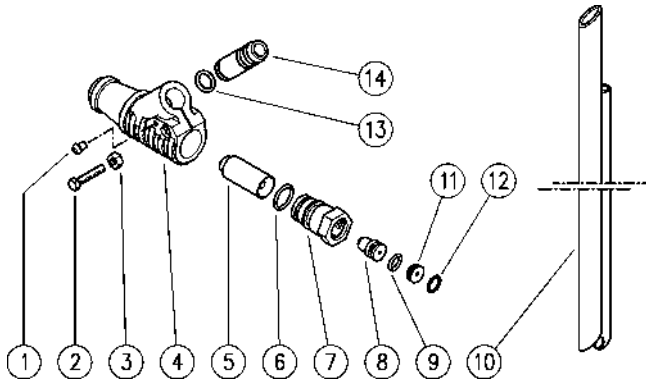

**25.0080.14 TS3-04 Sandblaster- plast.**

Pos.	P/N	Description	Q.ty	K1	K2	K3	K4	
1	15.2000.30	Stud, 03 white	1					10
1	15.2000.40	Stud, 04 dark yellow	1					10
2	16.1843.00	Screw, DIN7985 M4x20 mm z.pl.	1					10
3	11.4513.05	Hex. nut M4	1					10
4	25.0081.84	Casing -TS3	1					1
5	25.0083.61	Conveyor nozzle, 4,75 mm	1	•				5
6	10.3060.00	O-ring, 1,78x12,42 mm	1	•				10
7	25.0082.31	Nozzle holder -TS3	1					3
8	25.0007.51	Nozzle, 03 d.10,5x15 mm Sst.	1					5
8	25.0008.51	Nozzle, 04 d.10,5x15 mm Sst.	1					5
9	10.3052.00	O-ring, 1,78x6,75 mm	1	•				25
10	25.0013.21	Sand probe +13mm hose barb	1					5
11	25.0085.31	Nozzle insert	1	•				5
12	10.3003.00	O-ring, 1x8 mm	1	•				10
13	10.3057.00	O-ring, 1,78x9,25 mm	1	•				10
14	25.0084.31	13 mm hose barb -TS3	1					1

Kit	P/N	Description	
K1	25.0090.24	Spares kit -TS3 Sandblaster	1



P.A. S.p.A.  
Via Milano, 13  
42048 Rubiera, Reggio Emilia - Italy  
Tel +39.0522.623611  
Fax +39.0522.629600  
[info@pa-etl.it](mailto:info@pa-etl.it)

[www.pa-etl.it](http://www.pa-etl.it)



COMPANY WITH QUALITY MANAGEMENT  
SYSTEM CERTIFIED BY DNV  
= ISO 9001 =